

# GILSON MIXERS

**MORTAR-PLASTER MIXER  
MODEL: 800MP-OLD STYLE**

**OPERATOR'S GUIDE & PARTS MANUAL**

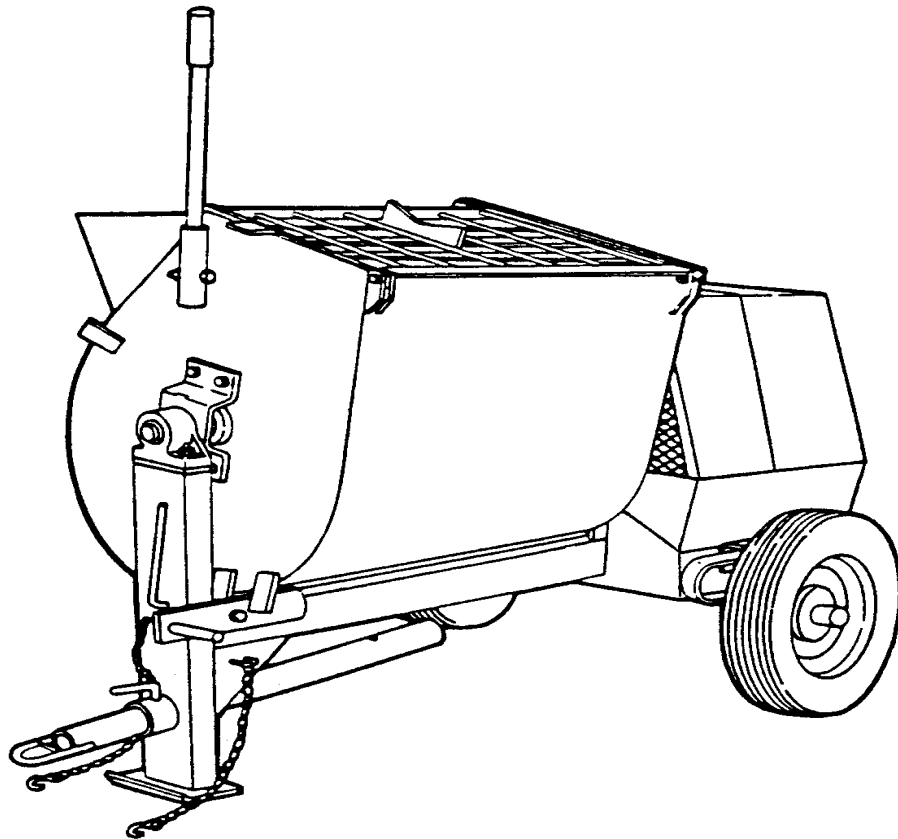

**GILSON MIXERS  
BY**



4343 Easton Road · St. Joseph, MO 64503  
816-233-4840 · 800-253-3676  
Fax 816-233-4624 · 888-253-3676  
E-Mail: [cleform@ccp.com](mailto:cleform@ccp.com)  
Web Address: [www.cleform.com](http://www.cleform.com)

## INTRODUCTION

This operator's manual has been prepared to provide the information you need to correctly operate and maintain your mixer. For maximum satisfaction, carefully read and follow the instructions in this manual. Should you need repair parts or service, refer to the parts breakdown on pages 14 through 25.

Information regarding operation and maintenance of the factory-installed engine or motor can be found in a separate engine/motor owner's manual supplied with the mixer. The manual prepared by the engine/motor manufacturer gives you the information necessary regarding engine adjustments, operation and maintenance. Should any questions arise concerning engine operation or service, contact the nearest engine/motor repair facility or dealer. For dealers in your area, consult the Yellow Pages under "Engines-Gasoline" or "Motors-Electric".

Be sure safety precautions are observed. Read and follow all safety and operating instructions in this operator's manual.

The replacement of any part on this product by other than the manufacturer's authorized replacement part may adversely affect the performance, durability, or safety of the product.

The manufacturer reserves the right to make changes on, or add improvements to its product at any time reserves the right to decide, upon its sole discretion and at any time, to discontinue a product.

**NOTICE: Record the model and serial numbers of your unit (located on the nameplate) in the spaces provided below. Engine model, type and code numbers are located on the engine blower housing, cylinder head or back plate.**

PRODUCT MODEL NUMBER: \_\_\_\_\_

PRODUCT SERIAL NUMBER: \_\_\_\_\_

ENGINE/MOTOR MODEL NUMBER: \_\_\_\_\_

ENGINE/MOTOR CODE NUMBER: \_\_\_\_\_

PURCHASE DATE: \_\_\_\_\_

DEALER PURCHASED FROM: \_\_\_\_\_

DEALER ADDRESS: \_\_\_\_\_

DEALER PHONE NUMBER: \_\_\_\_\_

# TABLE OF CONTENTS

<b>1. SAFETY PRECAUTIONS</b> .....	3
<b>2. ASSEMBLY AND PREOPERATIONAL CHECKS</b> .....	4
<b>3. CONTROLS AND OPERATION</b>	
Clutch Control Lever .....	5
Tow Pole Assembly .....	6
Safety Chains .....	6
<b>4. MIXER TRANSPORT</b> .....	7
<b>5. MIXER OPERATION</b>	
Operating the Mixer .....	7
Starting the Mixer .....	7
Extension Cords for Electric Motors .....	7
Loading the Mixer .....	8
Discharging the Mixer .....	8
Cleaning .....	8
Trouble Shooting Guide for MP Mixers .....	9
<b>6. OPERATING GUIDELINES</b>	
Masonry Construction Guidelines .....	10
<b>7. LUBRICATION</b>	
Drum Seal Housings .....	10
Mixing Shaft Bearings .....	11
Wheel Bearings .....	11
Drum Shaft Bearing Hangers .....	11
Engine/Motor .....	11
<b>8. ADJUSTMENT</b>	
Rubber Wiper Blades .....	12
Engine/Motor Drive .....	12
<b>9. STORAGE</b> .....	13
<b>10. PARTS LISTS AND POWER OPTIONS</b>	
Drum and Drive .....	14-15
Mixing Blades .....	16-17
Engine Housing Assembly .....	18-19
Frame Drive and Clutch Control .....	20-21
Engine and Power Options .....	22-25

# 1 – SAFETY PRECAUTIONS

**THE FOLLOWING PRECAUTIONS ARE SUGGESTED TO HELP PREVENT ACCIDENTS. A CAREFUL OPERATOR IS THE BEST OPERATOR. MOST ACCIDENTS CAN BE AVOIDED BY OBSERVING CERTAIN PRECAUTIONS. READ AND PRACTICE THE FOLLOWING PRECAUTIONS BEFORE OPERATING THIS EQUIPMENT TO HELP PREVENT ACCIDENTS. EQUIPMENT SHOULD BE OPERATED ONLY BY THOSE WHO ARE RESPONSIBLE AND HAVE BEEN PROPERLY INSTRUCTED.**

Read all operating and maintenance instruction before operating or servicing the mixer. Test run the empty unit prior to actual use.

A mixer is only as safe as its operator. Give complete and undivided attention to the operations of the mixer.

Know how to stop the mixer and engine/motor instantly in emergency situations.

Always keep all guard and safety devices and labels attached and in place before operating mixer. Close engine housing during mixer operation.

Keep inexperienced and unauthorized people away from the mixer at all times.

Never leave the mixer unattended when it is running

Shut off engine or disconnect electric power before making repairs or adjustments. **NEVER REACH INTO DRUM OR PLACE TOOLS INTO THE DRUM WHILE THE MIXER IS RUNNING.**

Do not overfill- -do not attempt to exceed the mixer's rated capacity.

Do not refuel the engine when it is hot or running.

Do not smoke while refueling the engine.

Block mixer wheels when in operation.

Keep the mixer well maintained and in good operating condition. Check periodically for loose or missing hardware.

Avoid loose clothing that could get caught in moving parts or on control levers. **KEEP HANDS AND FEET AWAY FROM MOVING PARTS.**

Never charge or fill the unit prior to starting the mixing blades as an overload encountered in starting a loaded unit could damage the engine/motor or drive components.

Connect safety chains only as instructed as noted in section 3 of this manual when towing the mixer. Connect only to a hitch, or pintle type coupler.

Keep warning, caution and safety instruction labels clean and in good condition. Replace missing, damaged or illegible labels.

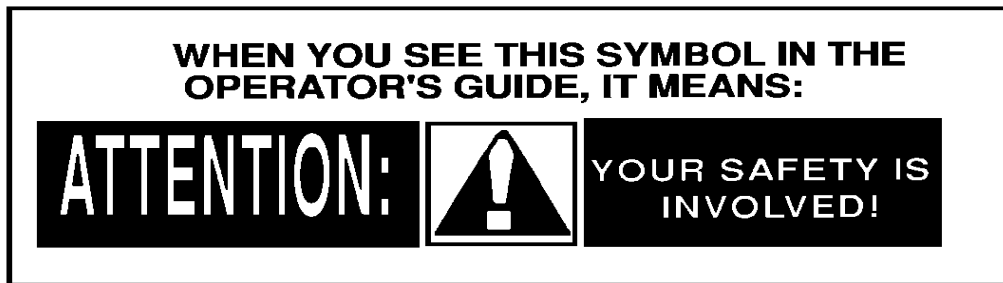

## **2 – ASSEMBLY AND PRO-OPERATIONAL CHECKS**

**The only assembly required on this mixer is the installation of the drum tilt handle. Remove the handle from the bag shipped in the drum and install, referring to parts list Figure 5, item numbers 7, 18, 20 and 21 for proper assembly.**

The following steps should be taken prior to placing the mixer in use:

1. The operator must be familiar with the location and operation of all controls.
2. Check the crankcase oil level on gasoline powered units, and fill the fuel tank before attempting to start.
3. Check for free rotation of the paddles and mixer shaft. Rotate the drum through one complete dump-charge-dump cycle. Make sure no foreign objects or tools are in the drum before starting engine/motor.
4. Start engine/motor, slowly engage the drum drive and check for smooth operation of the mixer blade shaft and drive.
5. Move the clutch lever through several cycles to assure correct clutch operation.

### 3 – CONTROLS AND OPERATIONS

1. The mixing paddles feature adjustable rubber wipers and steel backing plates. Paddles are factory preset for appropriate drum wrap clearance. If adjustment is required, proceed as follows:
  - A. Loosen the wiper attaching hardware and move the wiper outward to maintain contact with the drum but without folding over when in operation.
  - B. After adjustment, turn the mixer arms one full turn manually to check clearance and eliminate the possibility of wiper back plates contacting the drum.
2. Read through the manual for all operation, adjustment and maintenance instructions. Be sure all engine/motor and drive system operation instructions are followed as outlined.
3. All nuts and cap screws should be checked and tightened during the first two (2) hours of use. Periodic checks should be made thereafter.

### CLUTCH CONTROL LEVER



**WARNING:** To avoid personal injury, this control must be disengaged before starting engine/motor or when mixer is not in use.

This control is located in front of the mixing drum on the mixer leg. SEE FIGURE 1

This control engages and disengages the drive to the mixing blades.

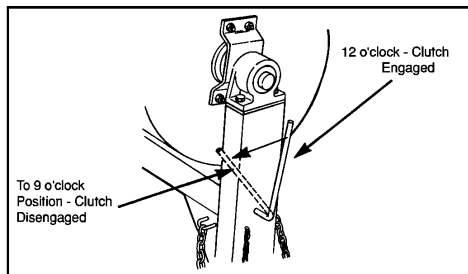

Figure 1.

**TO ENGAGE:** Position lever in line with the mixer frame (12 o'clock position). Lever is held in the engage position by the over-center action of the linkage.

**TO DISENGAGE:** Push lever down (counter-clock-wise) to the 9 o'clock position. Lever is spring loaded to hold it in the disengaged position.

## TOW POLE ASSEMBLY

The tow pole assembly is located on the front of the mixer and is used for transport only.

For transport, pull the tow pole assembly out, line up the hold and insert the L-shaped pin through holes.

When operating the mixer, pull the L-shaped pin out of the hole and push tow pole assembly all the way in. Line up the holes and insert the L-shaped pin through the holes.

## SAFTEY CHAINS



When transporting the mixer, slide the tow pole out as far as possible and insert the locking pin. When operating the mixer, slide the tow in and lock it in place.

Make sure drum is locked in position and engine housing is closed and secured.

1. Cross the chains **under** the tow pole to prevent the tow pole from dropping to the ground if the mixer comes loose.
2. Pass chain around a frame member or secure bumper iron and hook it back to itself for strongest attachment. If the chain hook is attached to a frame member or bumper iron or hole, it may slip off or the hook straightened out if the mixer comes loose. Attach chains securely.
3. Allow only enough slack in chains to permit proper turning of vehicles. To not let chains drag on ground, or to be drawn up too tight. Slack length should hold tow pole and front leg off the ground with the mixer loose. (SEE FIGURE 2)

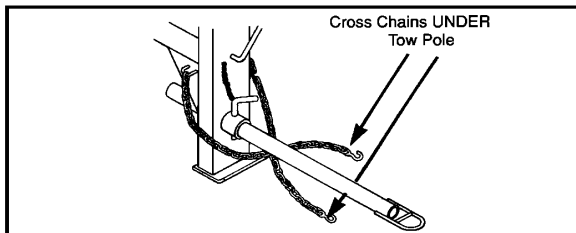

Figure 2.

**NOTE: SAFETY CHAIN LENGTH MAY NEED TO BE ALTERED FOR PROPER CONNECTION TO TOW VEHICLE. REPOSITION HOOKS, DO NOT CUT CHAIN.**

## 4 – MIXER TRANSPORT

1. Secure drum by engaging drum lock.
2. Secure all moveable parts, including the rear housing.
3. Secure tow pole coupler to vehicle and attach safety chains and hooks. (See **FIGURE 2**, Safety Chains).
  - A. Pintle type couplers require the appropriate tow vehicle coupler retainer.
  - B. Match ball coupler size exactly with hitch ball.

## 5 – OPERATING THE MIXER

### STARTING THE MIXER



**WARNING: To avoid personal injury, be sure clutch control lever is in the disengaged position before starting engine/motor.**

Start the mixer engine/motor. Refer to the engine/motor manual for proper starting procedures.

Prior to engaging clutch, lift drum latch from between transport lock blocks. Pull drum to dump position and lower drum latch to horizontal position. Return drum to operating position with transport lock block resting against drum latch lever. (Note: Rotation of paddles will hold drum into drum latch lever. SEE CAUTION DECAL ON MIXING DRUM)

When the engine/motor is warmed up and is running smoothly, move the control lever to the engaged position.

### EXTENSION CORDS FOR ELECTRIC MOTORS

The following size extension cords should be used: length of cord, up to 100 ft.-14 gauge wire; up to 200 feet-12 gauge wire; up to 300 feet-10 gauge wire; up to 400 feet-8 gauge wire.

**NOTE: Extension cord must be a 3-wire power cord and 3-wire power plug that is approved for outdoor use. When connecting the power cord, always connect cord to motor first and then plug into a grounded receptacle. When disconnecting the power cord, always unplug the grounded receptacle first.**

## LOADING THE MIXER

When the mixing blades are rotating, pour the required amount of water into the drum, then add cement, sand and lime.

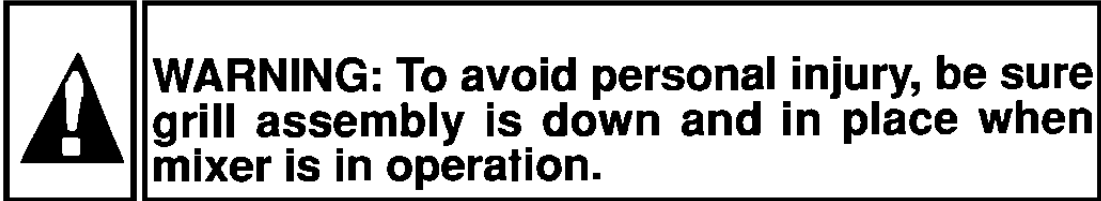

The desired mixing speed is 33 RPM

## DISCHARGING THE MIXER

Allow the entire mixture to mix for one (1) full minute. **DO NOT STOP MIXER FROM ROTATING.** Hold the tilt handle and disengage the drum lock. Dump mortar to the side by pulling the tilt lever downward.

After the mixture is dumped, return the drum to the operating position and engage drum lock.

## CLEANING

To achieve satisfactory performance from the mixer, it is essential to give the drum reasonable care. Clean the mixer after each use, before the mortar dries and becomes hard. Never permit mortar to harden on either the inside or outside of the drum. Do not pound or dent the drum as this impairs mixing efficiency and can cause spot wear on the drum surface. Spray the entire unit off after each use.

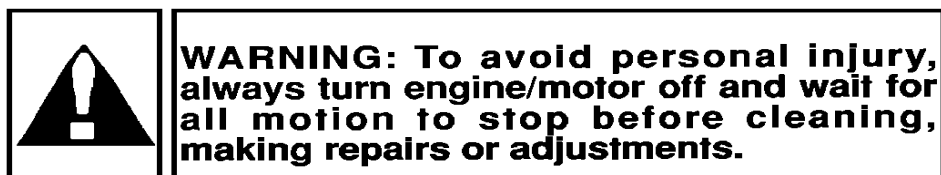

## TROUBLE SHOOTING GUIDE FOR MP MIXERS.

### ENGINE WON'T START:

1. Check for sufficient fuel.
2. Check oil level (some engines have an oil alert, preventing the engine from starting when oil level is low)
3. Was engine choked when starting?
4. Is engine flooded?
5. Check spark plug. (Clean and check gap).
6. If engine still won't start, take to service center.

### BELT DRIVEN MODELS:

1. Check condition of belts, replace if necessary.
2. Check for oil or grease on belts as well as for loose belts.
3. Adjust set screw under engine base down until belts are tight.

### TRANSMISSION DRIVEN MODELS.

#### CLUTCH SLIPS:

1. Remove spark plug wire.
2. Remove side cover on transmission.
3. Loosen set screw on clutch and adjust clutch clockwise a couple of notches at a time until paddles turn and have a firm pressure on the clutch handle.

#### TRANSMISSION TURNS BUT PADDLE ARMS WON'T:

1. Check if shear bolt on coupler is broken and has fallen out.

### HYDRAULIC DRIVEN MODELS.

#### PADDLE ARMS WON'T TURN:

1. Check if clutch rod has been bent or broken.
2. Check if flow control valve moves in forward position.

#### IF VALVE DOES NOT GO INTO FORWARD POSITION CHECK THE FOLLOWING:

1. Check if linkages are free.
2. Remove stem set screw (Fig 1) and put a few drops of oil in stem.
3. Replace set screw but do not overtighten.

#### PADDLE ARMS STOP WHEN DRUM IS FILLED:

1. Remove cap (Fig 2) and set pressure up by tightening threaded screw with allen wrench no more than ¼ turn at a time. Valve pressure is set at 1500 psi at factory. Each ¼ turn will increase the pressure by 250 psi. After each ¼ turn check to see if paddles turn (CAUTION) maximum pressure of valve is 3000 psi.

#### REVERSE TOO FAST OR TOO SLOW:

1. Loosen set screw on knob (Fig. 3)
2. Turn knob a small amount at a time clockwise to slow movement and counterclockwise to speed up movement

## 6 – OPERATING GUIDELINES

### MASONRY CONSTRUCTION GUIDELINES

The strength and durability of brick masonry depends upon the quality of the brick, the quality of the mortar and the workmanship in laying. The strength also depends upon adequate bond and the shape of the masonry unit.

*Brick quality* – Characteristics are hardness and density. Brick for masonry which is exposed to weather or where strength is desired should have a crushing strength of not less than 2500 PSI.

*Laying and bonding* – Brick should be laid in a full bed of mortar and shoved laterally into place to secure solid bearing, a bed of even thickness, and to fill the vertical joints. Brick should be thoroughly wet before laying, except in freezing weather. Bricks laid with the long dimension parallel to the face of the work are called stretches, perpendicular to the face are called headers. Bats (chalk bricks) should not be used except where necessary to make corners or to form patterns on the face of the walls. Walls are bonded or tied together longitudinally by overlapping stretches in successive courses. Transverse bond is obtained by making every sixth course headers with the headers themselves overlapping in successive courses in the interior of thick walls.

*Mortars* – Mortar composition is dependent on the structural use of the masonry unit. It is also dependent upon grade, weather exposure and climactic condition. Consult your brick or block supplier, the ACI (*American Concrete Institute*) Manual of Concrete Practices or your local building codes for the proper mortar selection for each application form more information.

## 7 – LUBRICATION



**WARNING: To avoid personal injury, always turn off engine/motor and wait for all motion to stop before cleaning, making adjustment or repairs.**

### DRUM SEAL HOUSINGS

Drum seals are provided on each end of the drum where the mixing shaft passes through to the bearings. It is important to pump grease into the housings through use to retain seal efficiency. Use enough grease to flush out old grease and carry away any grit. Use lithium based grade 2 multi-purpose grease. SEE FIGURE 3

## MIXING SHAFT BEARINGS

The mixing shaft bearings are permanently factory sealed and lubricated, and should not require further service.

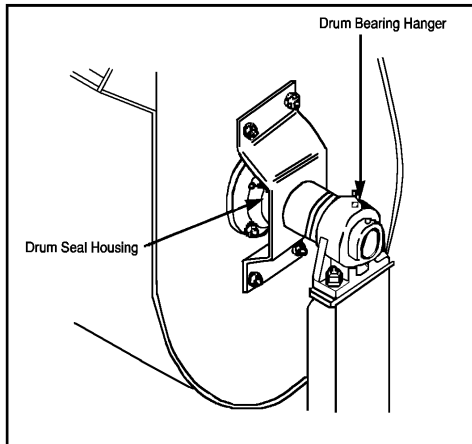

FIGURE 3.

## DRUM SHAFT BEARING HANGERS

Drum bearing hangers are located on each side of the drum, and are equipped with grease fittings. These bearings should be lubricated once each week with lithium based grade 2 multi-purpose grease. **SEE FIGURE 3**

## ENGINE/MOTOR

Refer to the engine/motor operating instructions for all maintenance and lubrication instructions and requirements.

## WHEEL BEARINGS

Wheel bearings should be packed once a year. Thoroughly clean old lubricant from the bearings, hub and spindles before repacking. Pack bearings only one-half to two-thirds full with grease to prevent overheating. Use no. 2 wheel bearing grease.

## JACK SHAFT BEARINGS

Pillow block style bearing are used on the drive train counter-shaft. See *Drum Seal Housing, Lubrication Guidelines* for more information. See *Figure 4* for bearing locations.

## 8 – ADJUSTMENT



**WARNING: To avoid personal injury, always turn off engine/motor and wait for all motion to stop before cleaning, making adjustment or repairs.**

### RUBBER WIPER BLADES

Adjust rubber wipers so they fit snugly against the drum but not to the point that they fold over when the blades rotate.

### ENGINE/MOTOR DRIVE

SEE FIGURE 4.

1. Align pulleys correctly
2. Tighten locking collars in the direction of rotation and tighten setscrews.
3. Adjust tension on the engine belt as follows:
  - A. Place clutch lever in the engaged (drive) position.
  - B. Move the engine/motor to tighten the belt until the engine plate is slightly above the horizontal position (about 1-2 degrees). Tighten engine/motor securely.
4. Adjust belt fingers so they do not touch the belt when the drive is engaged, but must allow disengagement of the belt when the drive is disengaged.
5. Adjust bull gear for minimum clearance of 3/16 inch from the pillow block stand and tighten both setscrews.

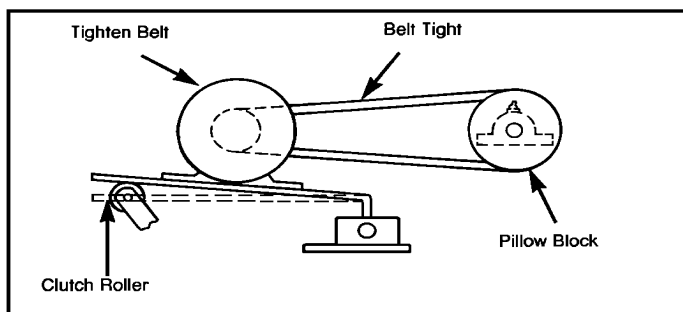

FIGURE 4.

## **9 – STORAGE**

For short term storage, clean the mixer and store in a dry place. If the mixer is not to be used for an extended period of time, service the mixer completely and store in a dry place.

1. Refer to the engine/motor instructions for storage instructions.
2. Cover exposed metal surfaces with a thin coat of SAE 30 weight engine oil.
3. Lubricate per instructions outlined in the LUBRICATION section.

**FIGURE 5**

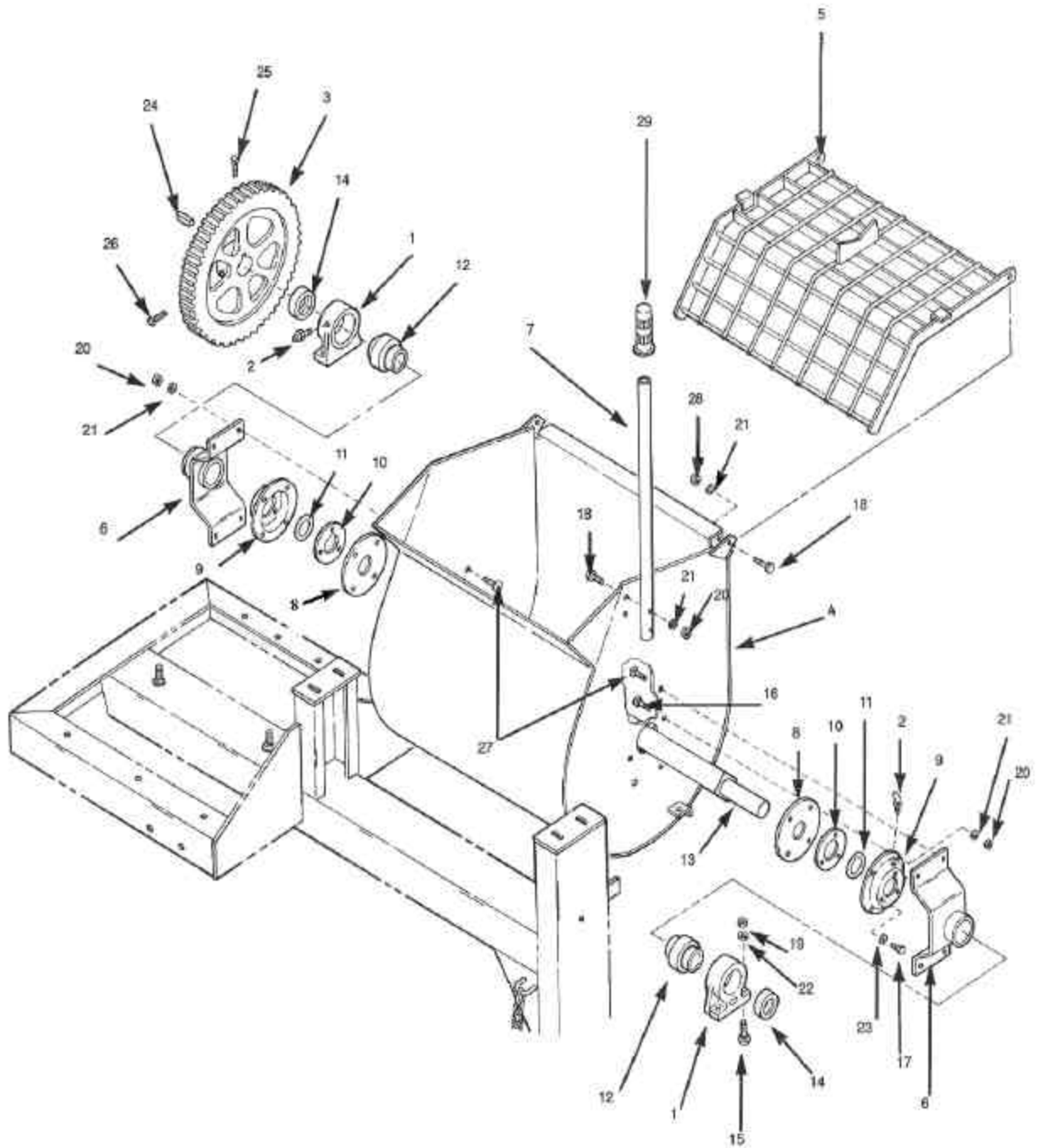

**DRUM and DRIVE**

Concrete Mixer Parts List

REF NO. PART NO. DESCRIPTION QTY LIST PRICE

**DRUM & DRIVE**

1	232255	Bearing Hanger	2	\$52.20
2	1031	Grease Fitting	4	\$1.30
3	214837	Gear	1	\$325.20
4	245420	Drum Sheel Assembly	1	\$452.00
5	245286	Grill Assembly	1	\$210.00
6	232392	Bearing Support Assembly	2	\$43.60
7	245704	Drum Tilt Lever	1	\$23.60
8	5771	Drum Seal	2	\$7.90
9	245349	Houseing, Seal	2	\$43.30
10	5772	O-ring Seal Clamp	2	\$8.40
11	5773	O-Ring	2	\$2.40
12	5776	Bearing, Drum shaft	2	\$42.50
13	245301	Drum Shaft	1	\$152.30
14	5777	Locking Collar	2	\$5.30
15	*70343	Capscrew, Hex Hd 1/2-13 x 1-1/2 GR 5	4	\$0.25
16	*70430	Capscrew, Flat Hd 3/8-16 x 1 1/4	8	\$0.25
17	*71259	Capscrew, Hex Hd 1/4-28 x 3/4 GR 5	6	\$0.25
18	*70258	Capscrew, Hex Hd 3/8-16 x 2 GR 5	4	\$0.25
19	*70563	Nut, Hex 1/2-13	4	\$0.25
20	*70553	Nut, Hex 3/8-16	18	\$0.25
21	*70649	Washer, 3/8 Spring Lock	20	\$0.15
22	*70655	Washer, 1/2 Spring Lock	4	\$0.15
23	*70643	Washer, 1/4 Spring Lock	6	\$0.15
24	*71018	Key, Square 5/16 x 2	1	\$1.00
25	*70073	Setscrew, Sq Hd Cup Pt 1/2-13 x 1	1	\$0.25
26	*70069	Setscrew, Sq Hd Cup Pt 1/2-13 x 1 1/4	1	\$0.25
27	*70429	Capscrew, Flat Hd 3/8-16 x 1	8	\$0.25
28	*70631	Nut, Cone Lock 3/8-16	2	\$0.25
29	1183	Grip, Drum Tilt Lever	1	\$2.40

\* LOCAL SOURCE

FIGURE 6

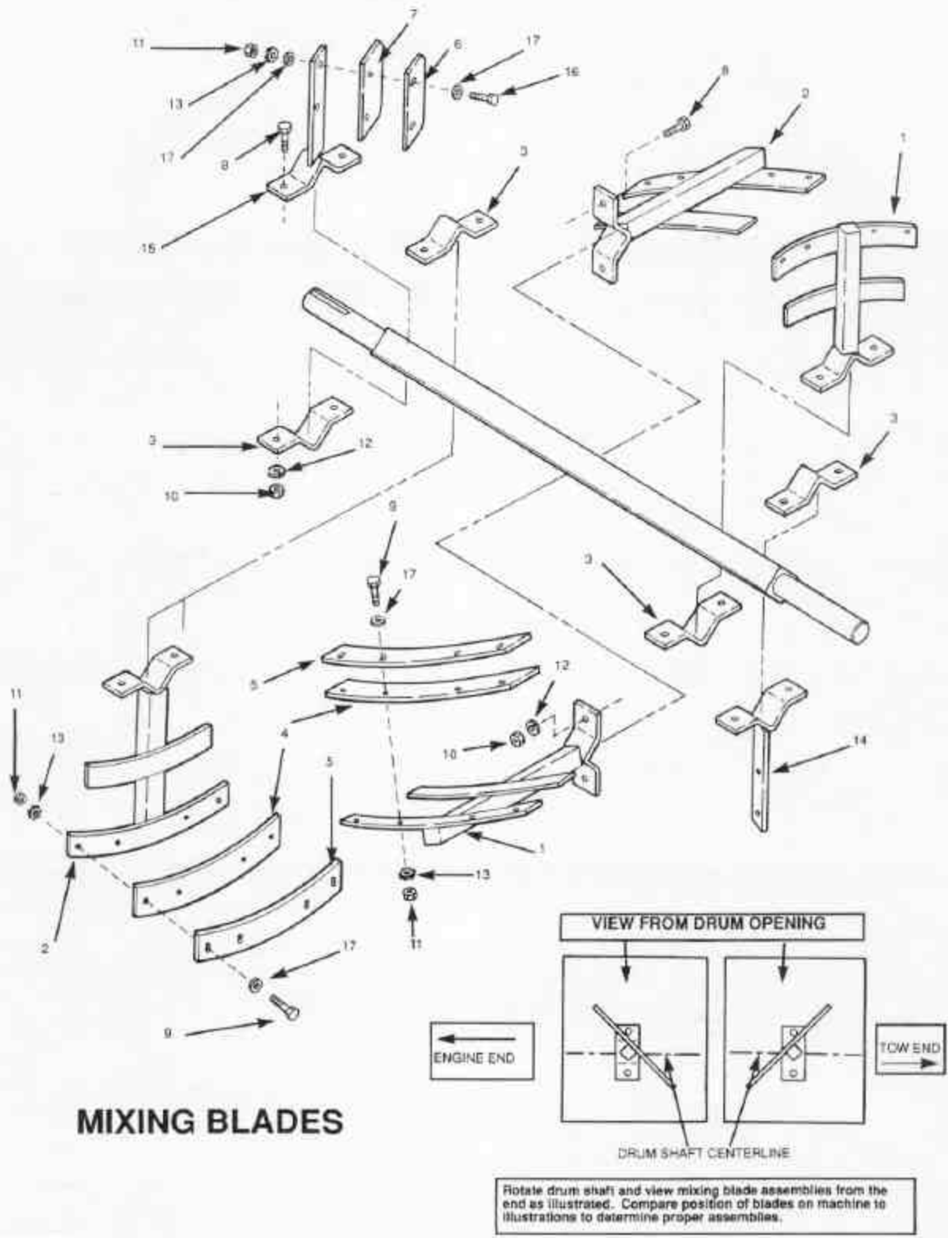

Concrete Mixer Parts List

**MIXING BLADES**

REF NO.	PART NO.	DESCRIPTION	QTY	LIST PRICE
1	245418	Mixing Arm Assembly, Tow End	2	\$59.10
2	245416	Mixing Arm Assembly, Engine End	2	\$59.10
3	245705	Mixing Arm Cap	4	\$10.80
4	232340	Drum Wrap Wiper	4	\$11.30
5	232341	Wrap Wiper Backing Plate	4	\$12.10
6	5230	End Wiper Backing Plate	2	\$6.60
7	5231	Drum End Wiper	2	\$8.90
8	*70343	Capscrew, Hex HD 1/2-13 x 1 1/2 Gr 5	10	\$0.25
9	*70164	Capscrew, Hex HD 5/16-18 x 1 1/4 Gr 5	16	\$0.25
10	*70563	Nut, Hex 1/2-13	10	\$0.25
11	*70549	Nut, Hex 5/16-18	20	\$0.25
12	*70655	Washer, 1/2 Spring Lock	10	\$0.15
13	*70646	Washer, 5/16 Spring Lock	20	\$0.15
14	245708	Side Arm Assembly, Tow End	1	\$31.50
15	245706	Side Arm Assembly, Engine End	1	\$31.50
16	*70164	Capscrew, Hex HD 5/16-18 x 1 1/2 Gr 5	4	\$0.25
17	*70701	Washer, 5/16 Flat	24	\$0.15

\*Local Source



4	232623 T-Handle Latch	2	\$10.50
5	5402 Handle, Engine Housing	1	\$6.30
6	220521 Rivet, Handle	4	\$0.70
7	223590 Rubber Bumper	4	\$1.10
8	232614 Housing Base Front Plate	1	\$25.50
9	213297 Screw, Thread Forming 5/16-18 x 1/2	6	\$0.35
10	*29065 Screw, Sheet Metal #10-24 x 3/8	4	\$0.25
11	232299 Axle Assembly	1	\$82.70
12	38565 Hub Assembly (includes:)	2	\$82.20
13	1046 Bearing Cup	4	\$5.30
14	1045 Bearing Cone	4	\$12.10
15	5037 Hub Cap	2	\$5.30
16	38567 Lug Nut	10	n/a
17	19981 Seal	2	\$10.50
18	232305 Axle Support Assembly	2	\$38.10
20	232385 Wheel and Tire Assembly		\$120.80
	232386 Wheel	2	n/a
	232387 Tire, A78-13	2	n/a
	10631 Valve Stem w/cap	2	n/a
21	*70339 Capscrew, Hex Hd 1/2-13 x 1 1/4 Gr 5	8	\$0.25
22	*70143 Capscrew, Hex Hd 5/16-18 x 3/4 Gr 5	6	\$0.25
23	*70563 Nut, Hex 1/2-13	8	\$0.25
24	*70942 Nut, 5/16-18 KEPS	4	\$0.25
25	*70610 Nut, Hex 10-24 KEPS	4	\$0.25
26	*70386 Screw, Rd Hd Machine 10-24 x 1/2	4	\$0.25
27	*70655 Washer, 1/2 Spring Lock	8	\$0.15
28	*70646 Washer, 5/16 Spring Lock	2	\$0.15
29	*70701 Washer, 5/16 Flat	10	\$0.15
30	*70727 Pin, Cotter 1/8 x 1 3/4	2	\$1.00
31	*70620 Nut, Hex Castle 3/4-16	2	\$0.25
32	*70713 Washer, 3/4 Flat	2	\$0.15
33	69500 Kit, Spring Axle (option) includes	1	\$225.00
34	245550 Bracket, Spring Mount RH	1	\$27.80
35	245549 Bracket, Spring Mount LH	1	\$27.80
36	232496 Spring	2	\$42.00
37	*70343 Capscrew, Hex Hd 1/2-13 x 1 1/2 Gr 5	12	\$0.25
38	*70563 Nut, Hex 1/2-13	12	\$0.25
39	*70655 Washer, 1/2 Spring Lock	12	\$0.15

\*-Local Source

FIGURE 9

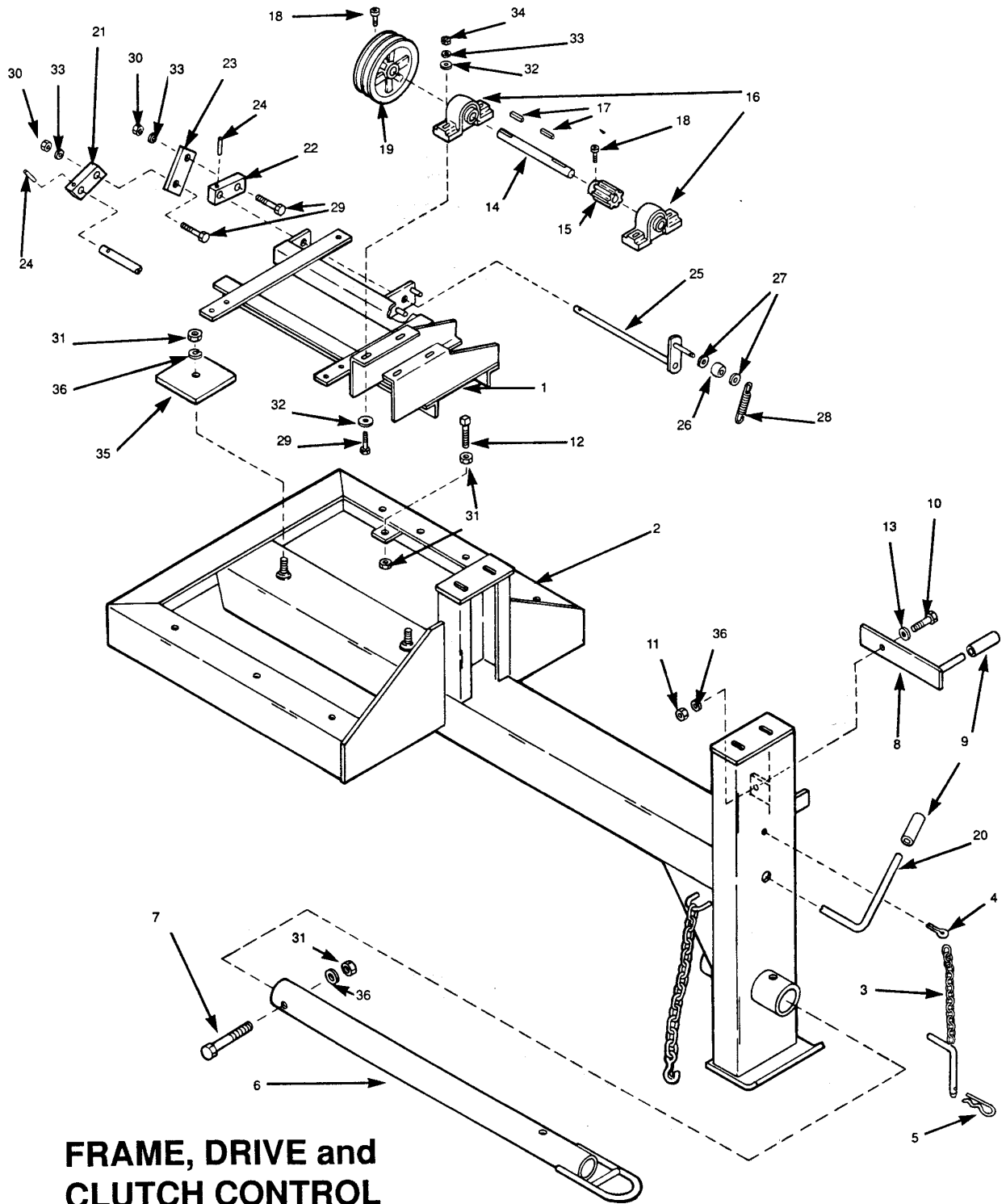

**FRAME, DRIVE and  
CLUTCH CONTROL**

Concrete Mixer Parts List

**FRAME, DRIVE AND CLUTCH CONTROL**

REF NO.	PART NO.	DESCRIPTION	QTY	LIST PRICE
1	245265	Frame, Engine and Drive Support	1	\$189.00
2	245281	Frame Assembly	1	\$708.80
3	232276	Pin and Chain Assembly	1	\$24.40
4	*70731	Pin, Cotter 3/16 x 1	1	\$1.00
5	*2776	Spring Clip	1	\$2.90
6	232301	Tow Pole Assembly Pintle (std)	1	\$86.60
7	*71215	Capscrew, Hex Hd 1/2-13 x 3 1/4 Gr 5	1	\$0.25
8	245426	Handle, Drum Lock	1	\$18.40
9	36282	Grip Handle	2	\$2.90
10	*70343	Capscrew, Hex Hd 1/2-13 x 1 1/2 Gr 5	1	\$0.25
11	*70581	Nut, 1/2-13 Jam	1	\$0.25
12	*70068	Setscrew, Sq Hd 1/2-13 x 3	1	\$0.25
13	*70707	Washer, 1/2 Flat	1	\$0.15
14	5242	Shaft, Pinion	1	\$54.10
15	5239	Gear, Pinion	1	\$99.80
16	5082	Bearing, Pillow Block	2	\$53.00
17	*70804	Key, 1/4 Sq x 2	2	\$1.00
18	*70498	Setscrew, Soc Hd 5/16-18 x 1/4 Cup Pt	4	\$0.25
19		Pulley, Driven (see ref #18, Fig 11A)		
20	245263	Shaft, Clutch Control	1	\$37.80
21	245264	Link, 3/8 and 5/8 holes	1	\$38.10
22	245328	Link, 3/8 and 1/2 holes	1	\$19.70
23	232263	Link, Clutch 6 inch	1	\$13.20
24	*70981	Pin, 3/16 x 1 3/8 Roll	2	\$1.00
25	245316	Clutch Rod Sub-Assembly	1	\$44.90
26	211689	Roller, Clutch	1	\$4.50
27	*70705	Washer, 7/16 Flat	2	\$0.15
28	232266	Spring, Overcenter	1	\$7.40
29	*70254	Capscrew, Hex Hd 3/8-16 x 1 3/4 Gr 5	6	\$0.25
30	*70631	Nut, 3/8-16 Cone Lock	2	\$0.25
31	*70563	Nut, 1/2-13	5	\$0.25
32	*15589	Washer, 3/8 Flat Thick 7/8 O.D.	8	\$0.15
33	*70649	Washer, 3/8 Spring Lock	6	\$0.15
34	*70553	Nut, Hex 3/8-16	4	\$0.25
35	245338	Clamp, Frame	2	\$18.90
36	*70655	Washer, 1/2 Spring Lock	4	\$0.15

\*-Local Source



Concrete Mixer Parts List

**ENGINE AND POWER OPTIONS**

REF NO.	PART NO.	DESCRIPTION	QTY	LIST PRICE
1	232412	Belt Guide, Upper	1	\$3.40
2	245339	Belt Guide, Lower (Angled Bracket)	1	\$13.50
3	*70631	Nut, Hex 3/8-16 Cone Lock	3	\$0.25
4	*70703	Washer, 3/8 Flat	4	\$0.15
5	232548	Pivot Blocks, Engine Plate	2	\$30.20
6	*70258	Capscrew, Hex Hd 3/8-16 x 2 Gr 5	4	\$0.25
7	*70553	Nut, Hex 3/8-16	4	\$0.25
8	*70649	Washer, 3/8 Spring Lock	4	\$0.15
9	*23156	Spring	1	\$5.00
10	*71404	Capscrew, Hex Hd 3/8-16 x 7 Gr 5	1	\$0.25
11	*70803	Key, 1/4 Square x 1 3/4	1	\$1.00
12	*70498	Setscrew, Soc Hd 5/16-18 x 5/16 Cup P	2	\$0.25
13	*70451	Capscrew, Carr Hd 3/8-16 x 1	1	\$0.25

\*-Local Source

FIGURE 11A

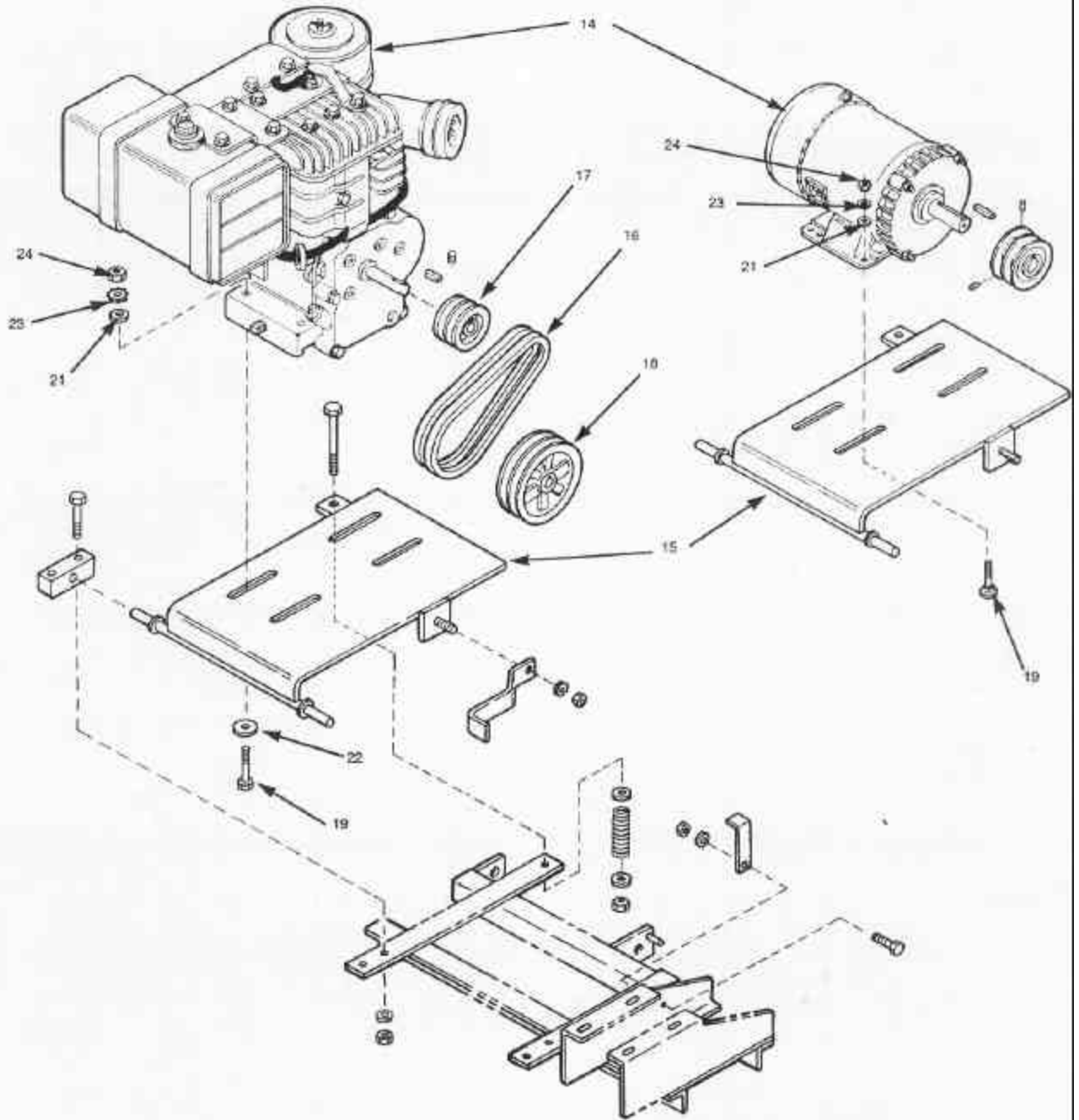

ENGINE and POWER OPTIONS

<b>Mixer Parts List</b>		<b>ENGINE AND POWER OPTIONS</b>	
REF. #	PART #	DESCRIPTION	QUANTITY
		<b>MP800 Model 59309</b>	
14	245200	Engine, Honda GX240HA 8 HP	1
15	245400	Engine Mount Plate	1
16	239969	Belts (set of 2)	1
17	5254	Pulley, Drive 5 3/4 O.D.	1
18	5240	Pulley, Driven 8 1/4 O.D.	1
19	*70170	Capscrew, Hex Hd 5/16-18 x 1 3/4 Gr 5	4
		<b>MP800 Model 59307</b>	
14	29055	Engine, Briggs & Stratton 170452 8HP	1
15	245400	Engine Mount Plate	1
16	239969	Belts (set of 2)	1
17	5254	Pulley, Drive 5 3/4 O.D.	1
18	5240	Pulley, Driven 8 1/4 O.D.	1
19	*70170	Capscrew, Hex Hd 5/16-18 x 1 3/4 Gr 5	4
		<b>MP800 Model 59347</b>	
14	245720	Engine, Wisconsin Robin 7.5HP	1
15	245400	Engine Mount Plate	1
16	239969	Belts (set of 2)	1
17	5254	Pulley, Drive 5 3/4 O.D.	1
18	5240	Pulley, Driven 8 1/4 O.D.	1
19	*70170	Capscrew, Hex Hd 5/16-18 x 1 3/4 Gr 5	4
		<b>MP800 Model 59310</b>	
14	201756	Engine, Wisconsin 7HP	1
15	245402	Engine Mount Plate	1
16	239969	Belts (set of 2)	1
17	239951	Pulley, Drive 3 7/16 O.D.	1
18	5240	Pulley, Driven 8 1/4 O.D.	1
19	*70258	Capscrew, Hex Hd 3/8-16 x 2 Gr 5	4
		<b>MP800 Model 59312</b>	
14	5405	Motor, Electric 2HP Single Phase	1
15	245404	Motor Mount Plate	1
16	239968	Belts (set of 2)	1
17	245430	Pulley, Drive 2 7/8 O.D.	1
18	239963	Pulley, Driven 12 1/4 O.D.	1
19	*70151	Capscrew, Hex Hd 5/16-18 x 1 Gr 5	4
20	*70804	Key, 1/4 Sq x 1 3/4	1
		<b>Additional Engine Mount Hardware-See Ref. 19 for Correct Size</b>	
21	*70703	Washer, 3/8 Flat	4
	*70701	Washer, 5/16 Flat	4
22	*15589	Washer, 3/8 Flat Large	4
23	*70649	Washer, 3/8 Spring Lock	4
24	*70553	Nut, Hex 3/8-16	4
	*70942	Nut, Hex 5/16-18 KEPS	4

\*Local Source

**CALL FOR PRICING ON THIS PAGE**

# **GILSON MIXER WARRANTY**

## **WARRANTY:**

This mixer is warranted to the original purchaser only, to be free of defects in material and workmanship under normal use, for one year from purchase date. Cleform Tool Corp. shall without charge, repair or replace parts which are found to be defective. All transportation charges for replacement parts must be borne to the purchaser.

For warranty service, the product must be delivered, with proof of purchase date, to the dealer of original purchase, or any factory authorized service dealer. The delivery of the unit must be made no later than 30 days after the expiration of the warranty period.

If difficulty is encountered in having the warranty work performed, contract the factory Service Department directly.

## **EXCLUSION FROM THIS WARRANTY:**

1. The following items are not covered under the CLEFORM TOOL CORP. One Year Limited Warranty and are warranted by the respective manufacturer.
  - a) Engines, including starters, generators, alternators and gear reducers.
  - b) Enclosed gear transmissions.
  - c) Hydraulic components, including pumps, motors and valves
  - d) A copy of the warranty and service contract information for the above items is furnished with the individual product.
2. All consequential damages, including pickup and delivery of the unit, communication, mileage charges and/or rental of a replacement unit during repairs are not covered under this warranty, nor is any loss of income and/or other loss resulting from the failure of the product to function due to a warranty defect.
3. This warranty will not apply when the product becomes inoperative due to misuse, normal wear, neglect, improper maintenance, accident or freight damage; has not been operated and maintained in accordance with the instructions furnished in the Operator's Manual; or has been altered or modified without approval from the factory Service Department.
4. No parts or products are to be returned to the factory without prior written approval from the factory.

**ALL IMPLIED WARRANTIES, INCLUDING THOSE OF MERCHANTABILITY AND FITNESS FOR A PARTICULAR PURPOSE, ARE LIMITED TO ONE YEAR FROM DATE OF PURCHASE BY THE ORIGINAL RETAIL CUSTOMER AND TO THE EXTENT PERMITTED BY LAW ANY AND ALL IMPLIED**

WARRANTIES ARE EXCLUDED AND DISCLAIMED AFTER THE EXPIRATION OF SUCH PERIOD.

Some states do not allow limitations on how long an implied warranty lasts, or the exclusion or limitations of incidental or consequential damages, so the above limitations or exclusions may not apply to you.

This warranty gives you specific legal rights, and you may also have other rights, which vary from state to state.

HOW TO OBTAIN PARTS AND SERVICE INFORMATION

For parts and service information, contact either your local dealer or the Cleform Tool Corp. factory:

CLEFORM TOOL CORP.  
4343 EASTON ROAD  
ST. JOSEPH, MO 64503  
800-253-3676 PHONE  
888-253-3676 FAX

HOW TO ORDER PARTS

When ordering parts be sure to indicate the following information:

- **Name of each part**
- **Complete part number**
- **Quantity of each part**
- **Model Name** (Include all letters and numbers)
- **Serial Number** (Include all letters and numbers)