

GILSON MIXERS

CONCRETE MIXER MODEL 900CM

OPERATING INSTRUCTIONS & PARTS LIST

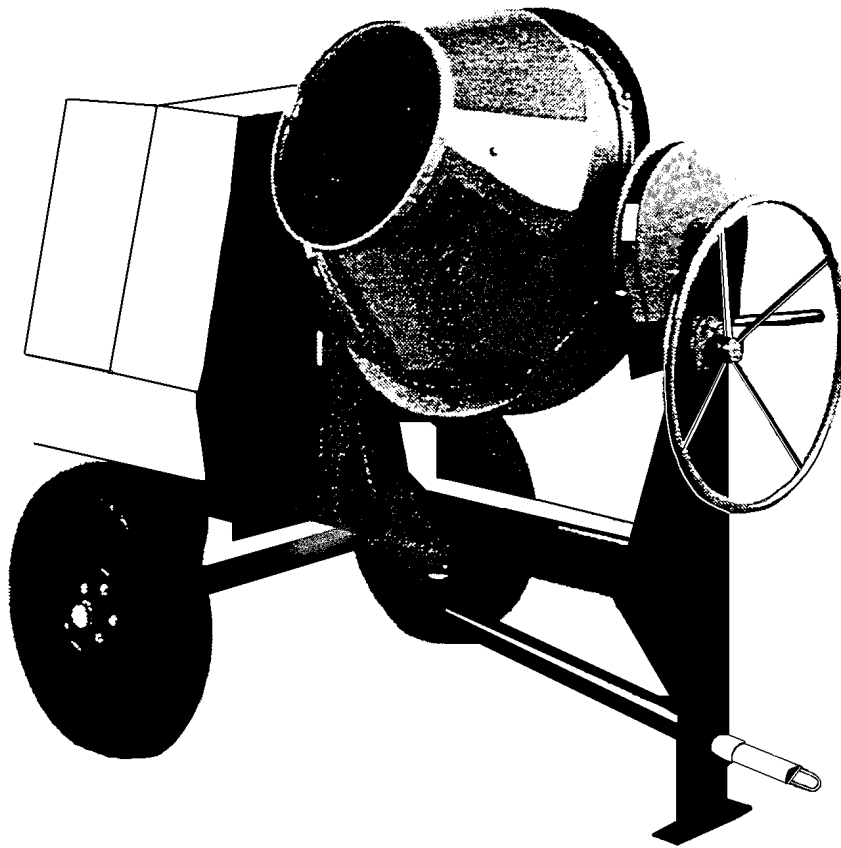

**GILSON MIXERS
BY**



4343 Easton Road · St. Joseph, MO 64503

816-233-4840 · 800-253-3676

Fax 816-233-4624 · 888-253-3676

E-Mail: cleform@ccp.com

Web Address: www.cleform.com

TO THE OWNER:

This owner’s manual provides the information needed to operate and maintain this Gilson mixer. Carefully read and follow all safety and operating instructions in this manual. Also, be sure every operator of this mixer reads this manual before operating the mixer. The replacement of any part on this mixer by other than the manufacturer’s authorized replacement part may adversely affect the performance, durability or safety of the product.

Be sure safety precautions are observed. Read and follow all safety and operating instructions in this operator’s manual.

The manufacturer reserves the right to make changes on, or add improvements to its product at any time without prior notice or obligation. The manufacturer reserves the right to decide, upon its sole discretion and at any time, to discontinue a product.

Information regarding operation and maintenance of the engine can be found in a separate engine manual supplied with this mixer if the mixer is supplied with an engine. The engine manual provides all the information required regarding engine adjustments, operation and maintenance. Should any questions arise concerning engine operation or service, contact the nearest engine repair facility or the engine manufacturer.

NOTICE: Record the model and serial numbers of the mixer (located on the nameplate) in the spaces provided. Engine model, type and code numbers are located on the blower housing, cylinder head or backplate.

Product Model Number: _____

Product Serial Number: _____

Engine/Motor Model Number: _____

Engine/Motor Code Number: _____

Purchase Date: _____

Dealer Purchased From: _____

Dealer Address: _____

Dealer Phone Number: _____

Table of Contents

1. Warranty Information	3
2. Safety Instructions, Pre-operational Checks	4-5
3. Lubrication	5-6
4. Care of Mixer	6
5. Batch/Mix Instructions	6
6. Parts Explosions and Lists	7

HOW TO OBTAIN PARTS AND SERVICE INFORMATION

For parts and service information, contact either your local dealer or the Cleform Tool Corp. factory:

CLEFORM TOOL CORP.
4343 EASTON ROAD
ST. JOSEPH, MO 64503
800-253-3676 PHONE
888-253-3676 FAX

HOW TO ORDER PARTS

When ordering parts be sure to indicate the following information:

- **Name of each part**
- **Complete part number**
- **Quantity of each part**
- **Model Name** (Include all letters and numbers)
- **Serial Number** (Include all letters and numbers)

WARRANTY:

This mixer is warranted to the original purchaser only, to be free of defects in material and workmanship under normal use, for one year from purchase date. Cleform Tool Corp. shall without charge, repair or replace parts which are found to be defective. All transportation charges for replacement parts must be borne by the purchaser.

For Warranty service, the product must be delivered, with proof of purchase date, to the dealer of original purchase, or any factory authorized service dealer. The delivery of the unit must be made not later than 30 days after the expiration of the warranty period.

EXCLUSIONS FROM WARRANTY:

1. The following items are not covered under the GILSON MIXER One Year Limited Warranty and are warranted by the respective manufacturer:
 - A. Engines, including starters, generators, alternators and gear reducers.
 - B. Enclosed gear transmissions.
 - C. Hydraulic components, including pumps, motors and valves
 - D. A copy of the warranty and service contact information for the above items are furnished with the individual product.
2. All consequential damages, including pickup and delivery of the unit, communication, mileage charges and/or rental of a replacement unit during repairs, are not covered under this warranty, nor is any loss of income and/or other loss resulting from the failure of the product to function due to a warranty defect.
3. This warranty will not apply when the product becomes inoperative due to misuse, normal wear, neglect, improper maintenance, accident, or freight damage; has not been operated and maintained in accordance with the instructions furnished in the Operator's Manual; or has been altered or modified without approval from the factory Service Department.
4. No parts or products are to be returned to the factory without prior written approval from the factory.

All implied warranties, including those of merchantability and fitness for a particular purpose, are limited to one year from date of purchase by the original retail customer and to the extent permitted by law any and all implied warranties are excluded and disclaimed after the expiration of such period.

Some states do not allow limitations on how long an implied warranty lasts, or the exclusion of limitations of incidental or consequential damages, so the above limitations and exclusions may not apply to you.

This warranty gives you specific legal rights, and you may also have other rights, which vary from state to state.

SAFETY INSTRUCTIONS

SAFETY PRECAUTIONS:



This is the industry's safety alert symbol. This symbol calls attention to items or operations that could be dangerous. This symbol can be found throughout this manual and on safety decals on the mixer. Read these messages carefully.

The following precautions are suggested to help prevent accidents. Read and practice the following precautions before operating this equipment. Equipment should be operated only by those who are responsible and have been properly instructed.

1. Read all operating and maintenance instructions before operating or servicing mixer. **Test run empty prior to actual use.**
2. A mixer is only as safe as its operator. Give complete and undivided attention to the operation of the mixer.
3. Know how to stop the mixer and the engine instantly.
4. Always have all guards and safety devices attached and in place before operating mixer. Close engine housing during operation.
5. Keep inexperienced and unauthorized people away from the mixer at all times.
6. Never leave the mixer unattended while it is running.
7. Shut off engine or disconnect the electric motor before making any adjustments or putting hands or tools in the drum.



NEVER REACH INTO THE DRUM OR PLACE TOOLS INTO THE DRUM WHILE THE MIXER IS RUNNING.

8. Do not overfill the drum. Do not exceed the mixer's rated capacity.
9. Do not smoke while refueling the engine. Shut off the engine and allow it to cool before refueling. Do not spill fuel.
10. Block mixer wheels when mixing.
11. Use safety chains while towing mixer.
12. Keep the mixer in good operating condition. Loose or damaged parts are dangerous.
13. Avoid loose clothing that could get caught in moving parts or on control levers.



KEEP HANDS AND FEET AWAY FROM MOVING PARTS.

14. Do not add material to the drum while stopped. Start the drum before adding material.
15. Keep all warning, caution and safety instruction labels in good condition. Replace missing, damaged or illegible labels.

TOWING & SAFETY CHAINS:

For transporting the mixer, slide the tow pole out as far as possible and insert the locking pin. When operating the mixer, slide the tow pole in and lock it in place.

Make sure drum is locked in position and engine housing is closed and secured.

Cross the safety chains under the tow pole and fasten them to the tow vehicle. (fig.1)

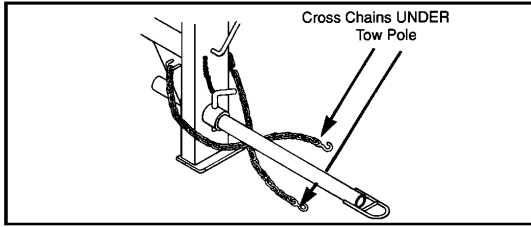

FIGURE 1

NOTE! Safety chain length may need to be altered for proper connection to tow vehicle. Reposition the hooks, DO NOT cut chain.

Allow enough slack to permit proper vehicle turning while keeping chains snug enough to prevent tow pole from contacting the ground in case the hitch uncouples.

PRIOR TO START UP:

1. Examine the mixer carefully to make sure there was no damage during shipment or since the last use. Report any damage immediately to the transportation company. Repair any damage before using the mixer.
2. Check for free rotation of the mixer drum yoke by rotating the drum through one complete dump-charge-dump cycle. Make sure no foreign objects or tools are in the drum before starting the motor.
3. Check the engine oil. Fill as required. Refer to the engine manual for oil specifications.
4. Fill the fuel tank with fresh, clean fuel. Refer to the engine manual for fuel specifications.
5. Grease all fittings as called out in the lubrication specifications.
6. Start the motor and check for smooth operation of the drum, ring gear, and pinion.

Note: After initial 10 hours of operations, check chain/belts for proper tension and sprockets/pulleys for alignment. Check these items monthly to prevent premature wear/failure.

LUBRICATION

Use lithium based grade 2 multi-purpose grease.

Drum Shaft Tube:

Drum shaft lubrication can be performed by removing the 1/8" pipe plug (item 4, fig3) and installing the appropriate grease fitting. Greasing should be done yearly.

Yoke Bearing Hangers:

Yoke bearing hangers are located on the yoke ends and are equipped with grease fittings. These bearings should be greased weekly.

Wheel Bearings:

Grease wheel bearings once per year. Thoroughly remove old grease from bearings and spindle before repacking. Pack bearings 1/2 to 2/3 full to prevent overheating.

Drum Tilt Brake Bearing:

The brake bearing casting is located near the front of the mixer and should be greased weekly.

Handwheel Bearing:

The handwheel hub bearing is located on the front of the mixer, behind the handwheel. This bearing should be greased weekly.

WARNING: DO NOT GREASE BRAKE BAND OR OUTER BRAKING SURFACE OF TILT GEAR.

Jack Shaft Bearings:

Pillow block style bearings are used on the drive train counter shaft. These bearings should be greased weekly.

Drive Chain:

The drive chain should be lubricated monthly with SAE #20 or SAE #30 oil. Apply the oil between the side plates.

Engine/Motor:

Refer to the manufacturer's engine or motor operating instructions for all maintenance and lubrication requirements and instructions.

LUBRICATION FREQUENCY CHART:

#	ITEM	FREQUENCY	FIGURE	CODE	PLACES
1	Yoke Bearing Casting	weekly	3	grease	2
2	Handwheel Hub	weekly	4	grease	1
3	Drum Tilt Brake Bearing Casting	weekly	4	grease	1
4	Drive Shaft & Jackshaft	weekly	4	grease	1
5	Drum Shaft Tube	yearly	3	grease	1
6	Wheel Bearings	yearly	1	grease	2
7	Drive Chain	monthly	4	oil	1

MIXING INSTRUCTIONS:

1. Start the drum rotating.
2. Add water.
3. Add cement and one shovelful of coarse aggregate. The coarse aggregate will break up any lumps in the cement.
4. Add remaining aggregate: crushed stone, pit-run gravel or sand.
5. Mix batch for approximately one minute. Drum speed should be about 25 r.p.m.

CARE OF MIXER:

It is important to keep the inside of the mixing drum free of hardened concrete. After discharging the last batch of concrete each day, add a pailful of water and two shovelfuls of gravel to the drum. This will scour the inside of the drum. Mix for about two minutes, discharge and rinse the drum with water.

ENGINE HOUSE, WHEEL & AXLE

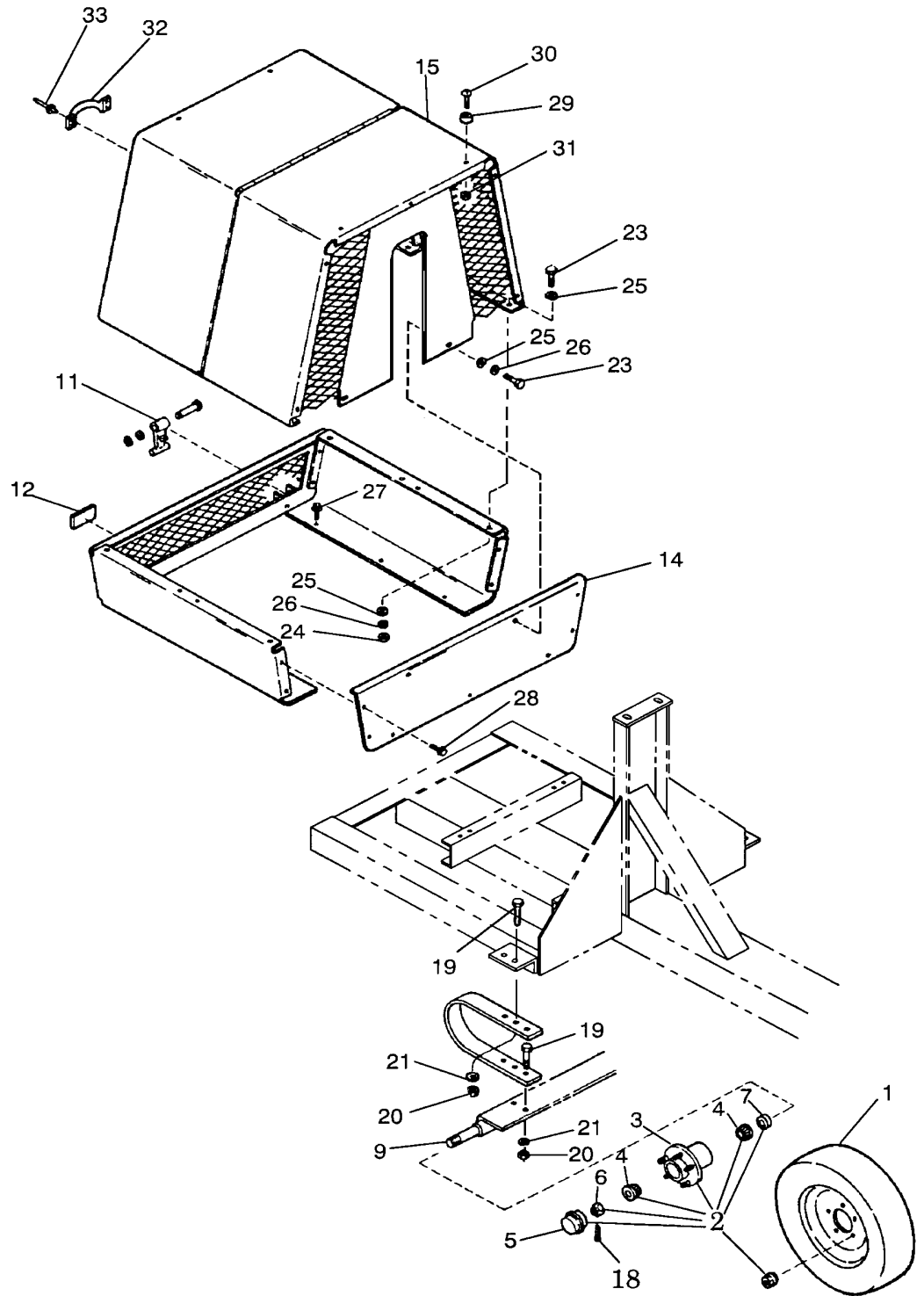

FIGURE 1

Concrete Mixer Parts List

Item	Part No.	Description	Qty
1	232385	Wheel, Tire and Valve Assembly	2
2	38565	Hub Assembly	2
8	232489	Axle Assembly	1
9	232496	Suspension Spring	2
10	245843	Suspension Bumper	2
11	232623	T-Handle Latch	2
12	32082	Reflector, Red	2
13	245470	Housing Base Assembly	1
14	232614	Housing Base Front Plate	1
15	232533	Housing Sub-Assy.- Includes Front & Back w/Hinge	1
18	*	Pin Cotter 1/8 x 1 1/2" (supplied with hubs)	2
19	70343*	Capscrew, Hex Head 1/2-13 x 1 1/2, Plated, Grade 5	8
20	70563*	Nut, 1/2-13, Plated	8
21	70655*	Washer, 1/2 Spring Lock, Plated	8
22	70696* ¹	Washer, Flat SAE 3/4 Plated	2
23	70143*	Capscrew, Hex Head, 5/16-18 x 3/4, Plated Grade 5	6
24	70549*	Nut, 5/16-18	4
25	70701*	Washer, 5/16 Flat	10
26	70646*	Washer, 5/16 Spring Lock	4
27	213297*	Screw, Thread Forming, 5/16-18 x 1/2	6
28	29065*	Screw, Sheet Metal #10-24 x 3/8	4
29	223590	Rubber Bumper	2
30	70387*	Screw, Round Head Slotted, #10-24 x 3/4, Plated	4
31	70627*	Nut, #10-24 UNC Lock Nut, Nylon Insert, Zinc Plated.	4
32	5402	Handle, Engine House	1
33	220521	Rivet, Handle	4
34	245845 ¹	Engine House Spacer	2

* Use Local Source ¹ Not Shown

Frame, Engine Base and Tow Pole

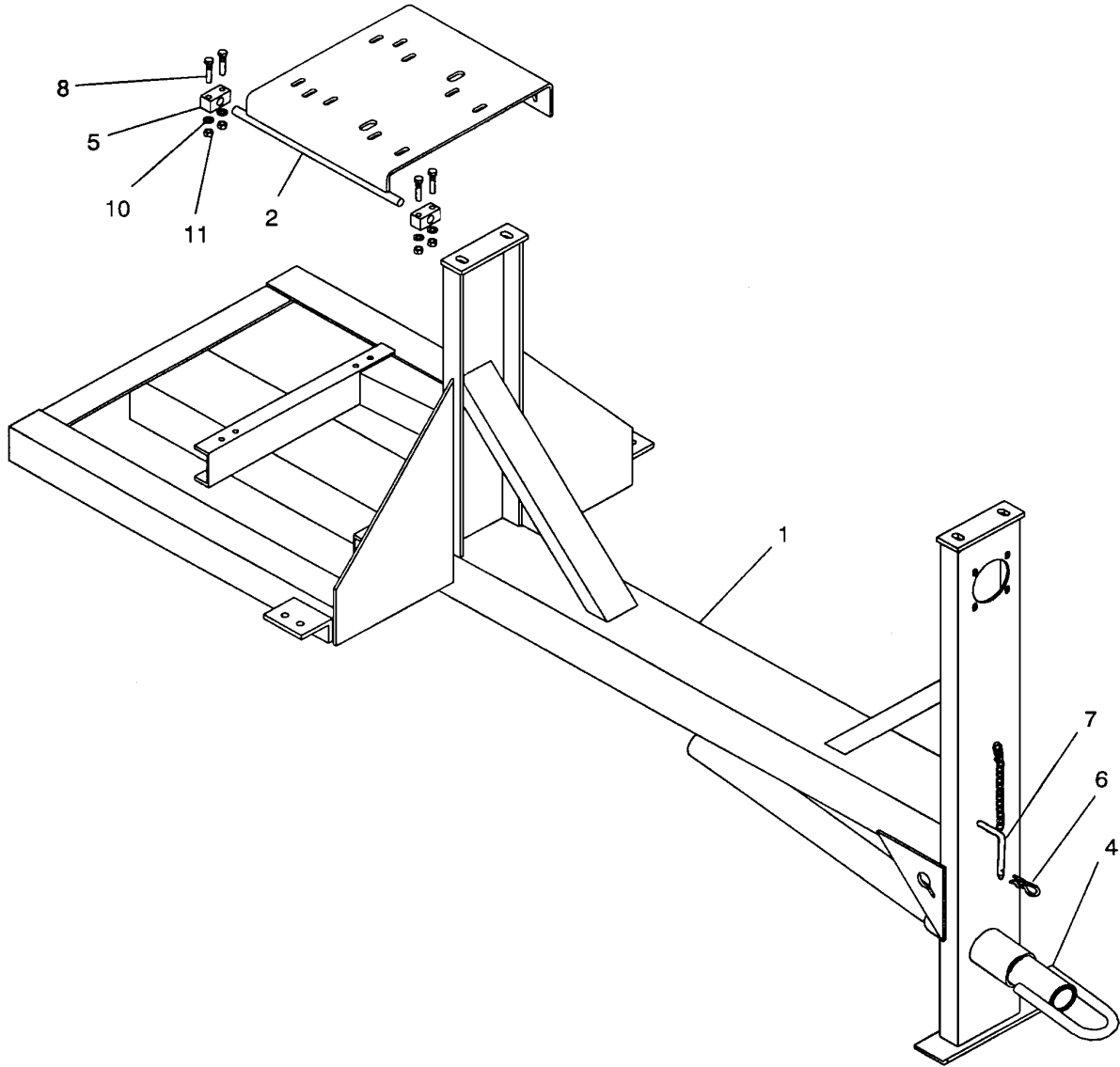

Figure 2

Concrete Mixer Parts List

Item	Part No.	Description	Qty
1	773-40325	Frame	1
2	773-40338	Engine Base Plate Assembly	1
3	773-40339	Height Adjust Angle for Engine Mount	1
4	773-40546	Tow Pole Assembly	1
5	773-40340	Engine Base Pivot Block	2
6	2776	Spring Clip	1
7	23276	Tow Pole Pin and Chain Assembly	1
8	70258*	HHCS, 3/8-16 x 2, Zn Pl	4
9	70233*	HHCS, 3/8-16 x 1, Zn Pl	4
10	70649*	3/8 Lockwasher, Zn Pl	8
11	70553*	Hex Nut, 3/8-16, Zn Pl	8

* Use Local Source

DRUM AND YOKE PARTS

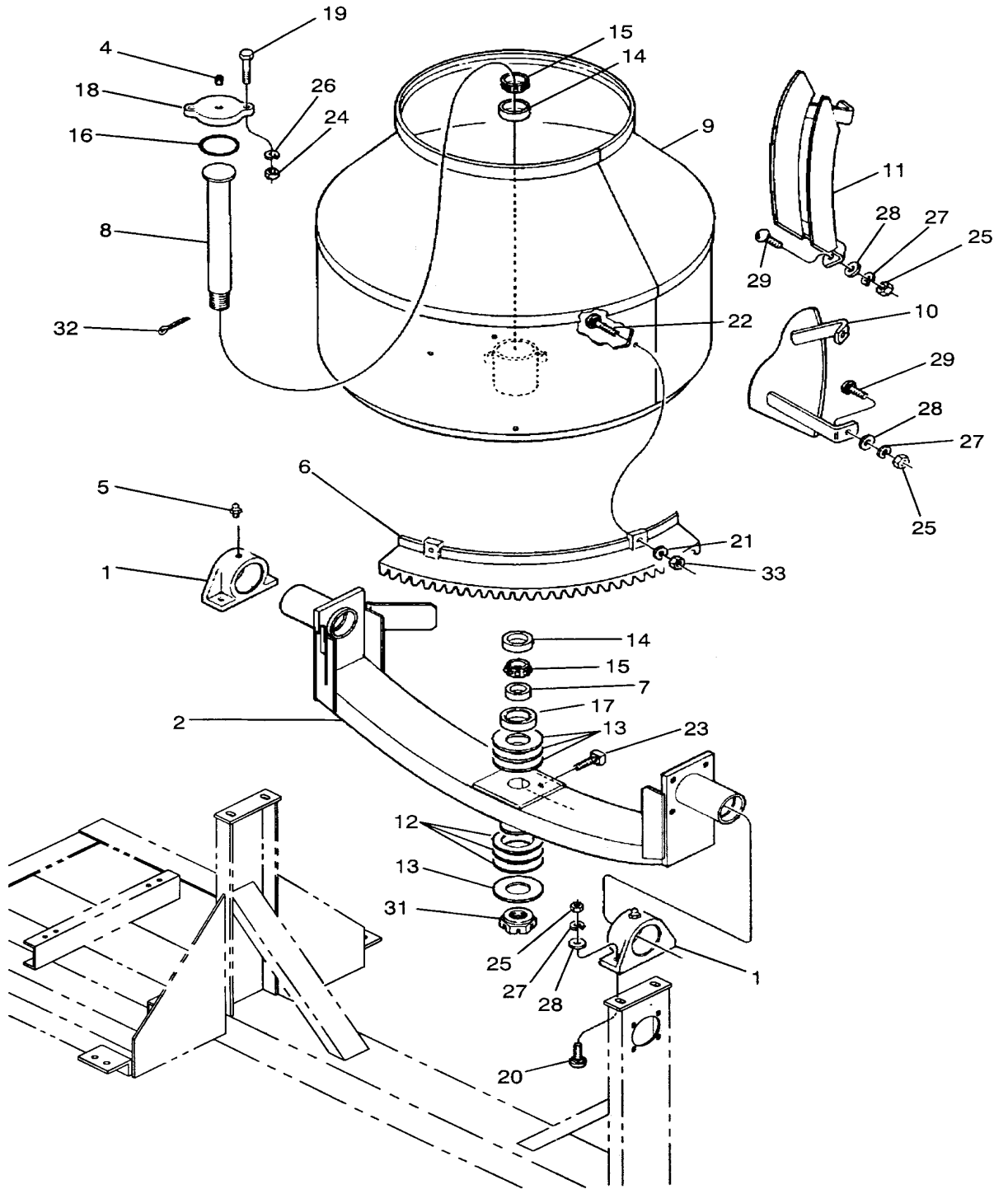

FIGURE 3

Concrete Mixer Parts List

Item	Part No.	Description	Qty
1	773-40337	Yoke Bearing	2
2	5962	Yoke Assembly	1
3	29533	Yoke Washer (Not Shown)	1
4	29199	Pipe Plug, 1/8" w/Hex Socket	1
5	1031	Grease Fitting	2
6	245245	Ring Gear Segment	5
7	5755	Drum Shaft Spacer	1
8	5945	Drum Shaft Assembly	1
9	5977	Drum Assembly	1
10	5959	Bottom Blade	2
11	5960	Top Blade	2
12	5872	Washer - Drum Shaft	3
13	5975	Shim - Drum Shaft	AR
14	5980	Drum Bearing Cup	2
15	5981	Drum Bearing Cone	2
16	5982	Drum Shaft O-Ring Seal	1
17	5983	Drum Shaft Bearing Seal	1
18	5963	Drum Hub Cover Assembly	1
19	70179*	Cap Screw, Hex Hd. 5/16 -18 x 2 1/4 Plated, Grade 5	2
20	70242*	HHCS, 3/8-16 x 1 1/4 Zn PI	4
21	70716*	Fender Washer, 2 OD x 17/32 ID, Zn PI	10
22	70339*	HHCS, 1/2-13 x 1 3/4	10
23	70489*	Set Screw, Square Cup Pt. 5/8-11 x 2 1/4	1
24	70549*	Nut, Hex, 5/16-18	2
25	70553*	Nut, Hex, 3/8-16, Plated	14
26	70646*	Washer, Spring Lock, 5/16	2
27	70649*	Washer, Spring Lock, 3/8 Plated	4
28	70703*	Washer, Flat 3/8	10
29	70905*	Carriage Bolt, 3/8-16 x 1	8
30	70906*	Carriage Bolt, 3/8-16 x 1 1/4	2
31	71001*	Nut, Hex Slotted, 1 1/4-12	1
32	71008*	Pin, Cotter, 3/16 x 2"	1
33	70563*	Nut, Hex, 1/2-13, ZN PI	10

* Use Local Source

DRIVE AND TILT PARTS

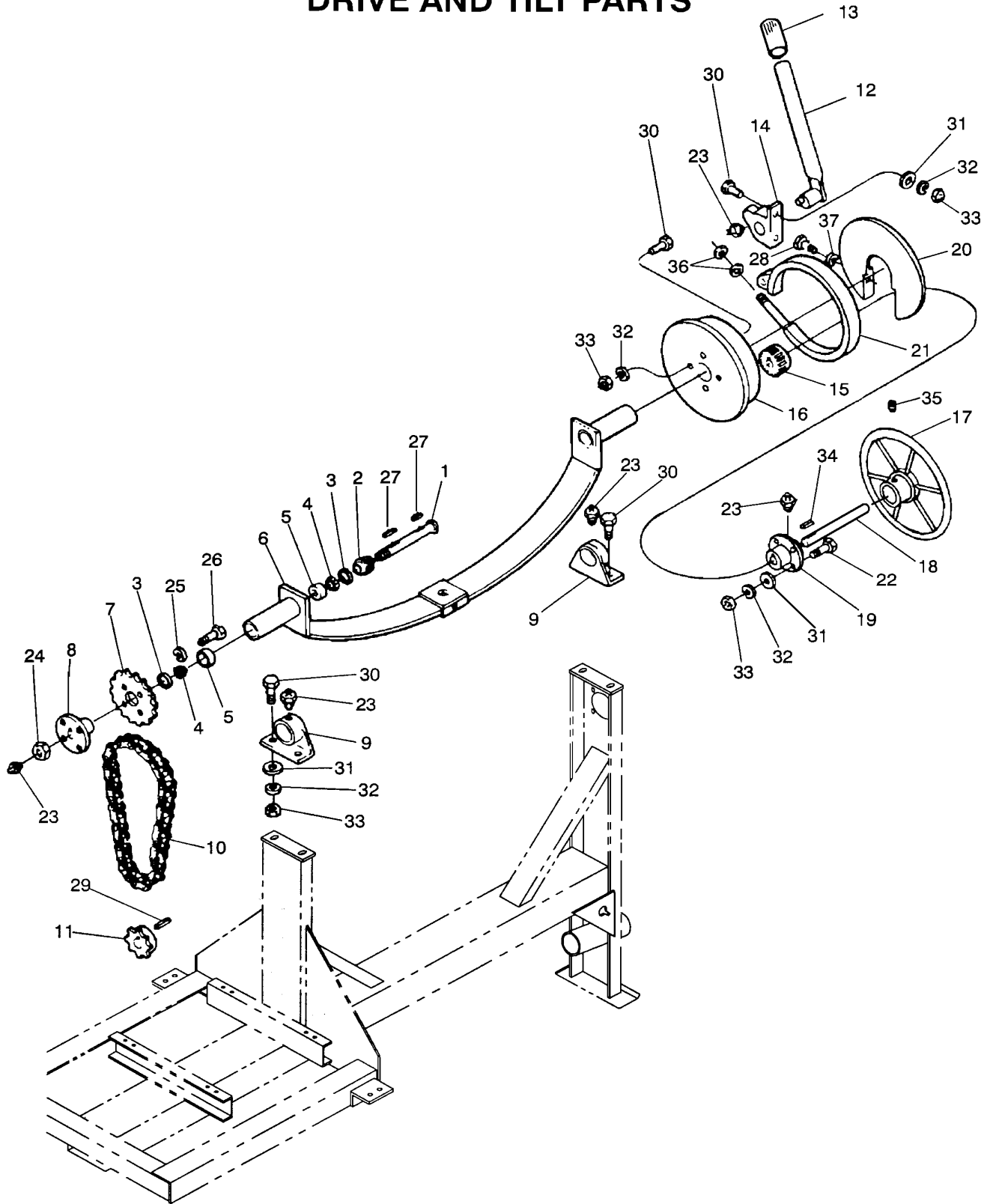

FIGURE 4

Concrete Mixer Parts List

Item	Part No.	Description	Qty
1	19060	Drive Shaft Assembly	1
2	5950	Drive Pinion	1
3	5008	Drive Shaft Bearing Seal	2
4	4298	Drive Shaft Bearing Cone	2
5	4299	Drive Shaft Bearing Cup	2
6	5962	Yoke Assembly	1
7	5956	Sprocket, Driven	1
8	5953	Sprocket Hub	1
9	773-40337	Yoke Bearing	2
10	19767	#60 Rivited Type Roller Chain (Number of links varies by model)	1
	19778	#60 Connecting Link	1
	19779	#60 Offset Link (Not used on all models)	1
11	5641	15T Drive Sprocket, WI Engine Models	1
	5958	18T Drive Sprocket, All Other Models	1
12	19087	Break Lever Assembly	1
13	1183	Break Lever Grip	1
14	5941	Break Bearing	1
	773-40378	Brake Bearing Spacer ¹	1
15	5949	Tilt Pinion	1
16	5951	Internal Tilt Gear	1
17	5961	Handwheel	1
18	5947	Shaft, Tilt Pinion	1
19	5944	Handwheel Bearing	1
20	29470	Tilt Gear Cover	1
21	5955	Brake Band	1
22	70242*	3/8-16 x 1 1/4 HHCS, Zn Plated	4
23	1031	Grease Fitting	5
24	5449	Drive Shaft Lock Nut	1
25	70646*	5/16 Lockwasher, Zn Plated	4
26	70151*	5/16-18 x 1 HHCS, Zn Plated	4
27	29437*	Key, 5/16 x 1/4 x 1 1/4	1
28	70097*	1/4-20 x 3/4 HHCS, Zn Plated	2
29	70804*	Key, 1/4 Sq x 2	1
30	70249*	3/8-16 x 1 1/2 HHCS Zn Plated	10
31	70703*	3/8 Washer, Flat, Zn Plated	10
32	70649*	3/8, Lockwasher, Zn Plated	14
33	70553*	3/8-16 Hexnut, Zn Plated	14
34	71021*	Key 3/8 Sq x 1 3/4	2
35	70512*	3/8-24 UNF x 3/8 Socket Head Set Screw	2
36	70581*	1/2-13 Hex Nut Jam, Zn Pl	2
37	70643*	1/4 Regular Lockwasher, Zn Pl	2
38	70655*	1/2 Regular Lockwasher, Zn Pl	2
39	71008* ¹	3/16 x 2 Cotter Pin	1
40	* ¹	5/32 x 1 1/2 Cotter Pin	1

* Use Local Source ¹ Not Shown

POWER OPTIONS

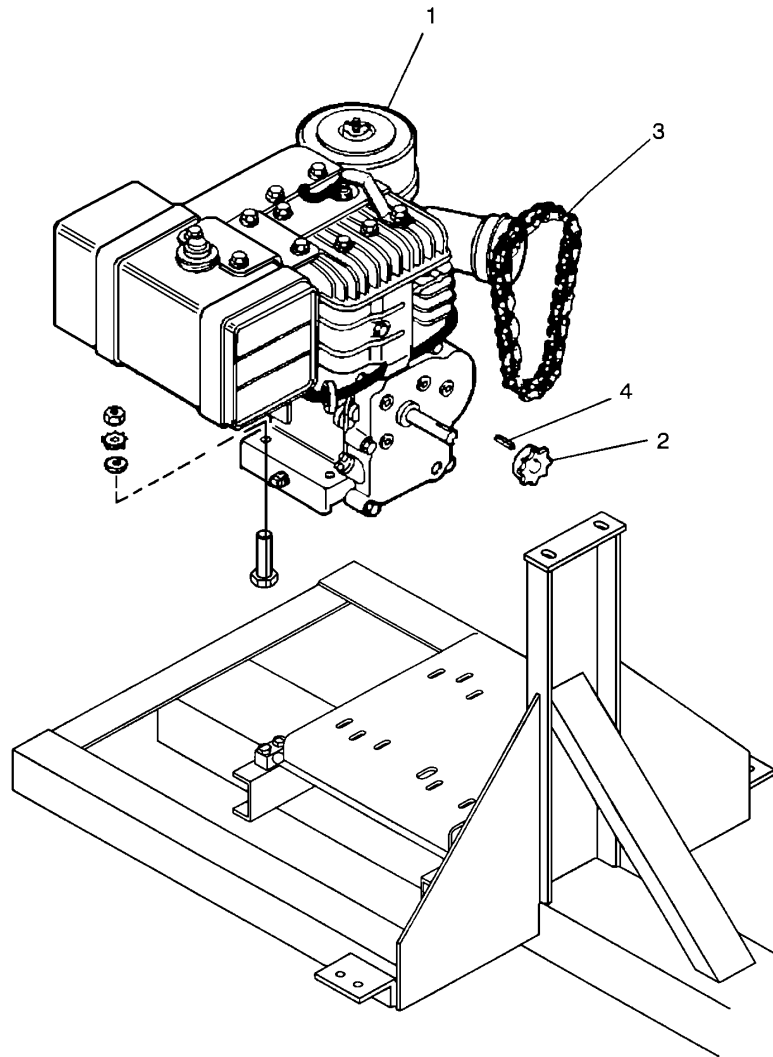

MODEL 59278 8 HP HONDA

ITEM	PART NO	DESCRIPTION	QTY
	1	245200 Honda 8 HP GX240 W/6:1 Reduction	1
	2	5958 Drive Sprocket 18T	1
	3	5978 #60 Riveted Type Roller Chain, 4.6 FT (Includes links listed below)	1
		19778 #60 Connecting Link (Included w/item #3)	1
		19779 #60 Offset Link (Included with item #3, not used on all models)	1
	4	70800 1/4 x 1 Square Key	1
	<input type="checkbox"/>	70235 3/8-16 x 1" lg HHCS Zn Plated, Gr 5	4
	<input type="checkbox"/>	70266 3/8-16 x 2 1/2" lg HHCS Zn Plated, Gr 5	4
	<input type="checkbox"/>	70390 #10-24 x 1 1/4" lg Machine Screw, Slotted Round Head, Plain Finish	3
	<input type="checkbox"/>	70540 #10-24 Hex Nut, Zn Plated	7
	<input type="checkbox"/>	70913 #10-24 x 3/4" lg Machine Screw, Slotted Round Head, Plain Finish	4
	<input type="checkbox"/>	Not Shown - Use Local Source	

POWER OPTIONS

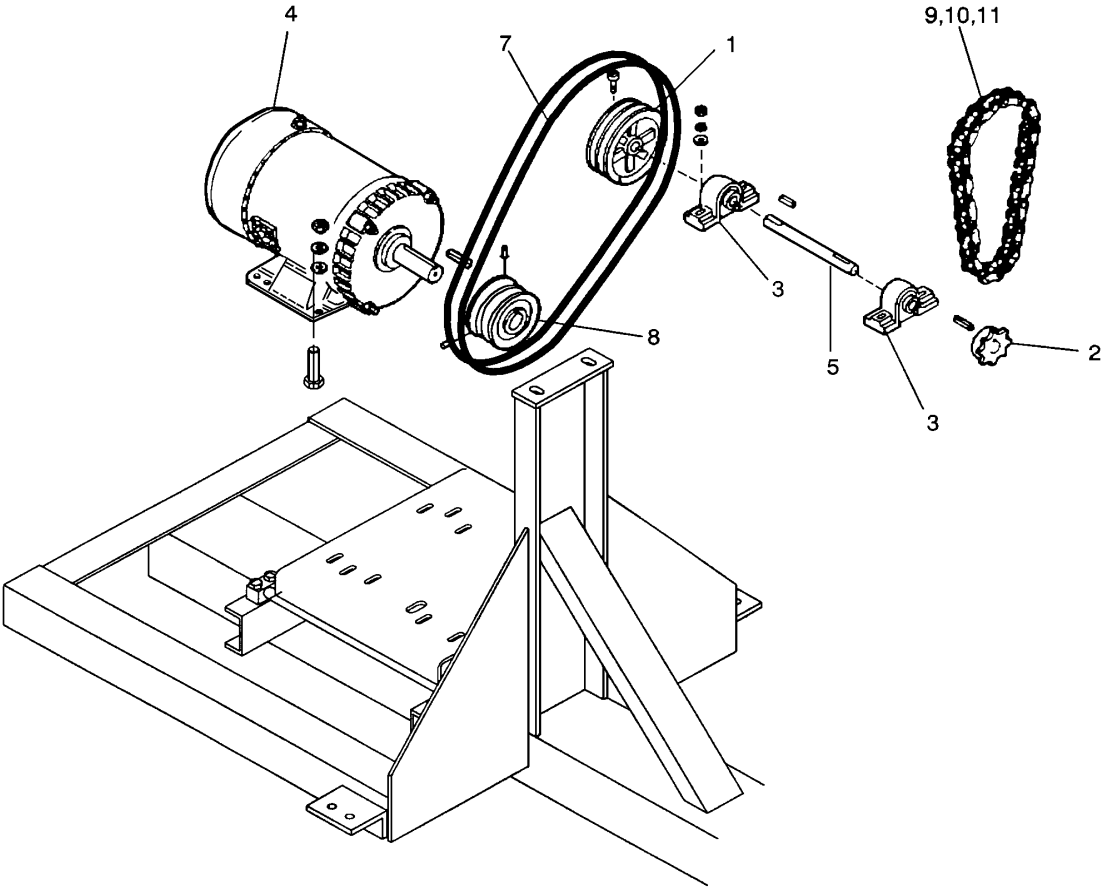

MODEL 59280 3 HP 1 ELECTRIC MOTOR

ITEM	PART NO	DESCRIPTION	QTY
1	210014	Countershaft Pulley	1
2	5994	15T Countershaft Sprocket	1
3	5082	Countershaft Pillow Block Bearing	2
4	5328	Electric Motor, 3HP Single Phase	1
5	5464	Countershaft for Electric Motor Kit	1
6	5466	Countershaft Bracket Assembly	1
7	5591	V-Belt	2
8	5887	Sheave	1
9	5990	#60 Riveted Type Roller Chain, 4.0 FT (Includes links listed below)	1
10	19778	#60 Connecting Link (Included with Item #9)	1
11	19779	#60 Offset Link (Included with Item #9)	1
<input type="checkbox"/>	70235	3/8-16 x 1" lg GR 5 HHCS Zn Plated	4
<input type="checkbox"/>	70238	3/8-16 x 1 1/8" lg GR 5 HHCS Zn Plated	4
<input type="checkbox"/>	70390	#10-24 x 1 1/4" lg Machine Screw, Slotted Round Head, Plain Finish	3
<input type="checkbox"/>	70500	5/16-18 x 1/2" lg Socket Head Cup Set Screw	1
<input type="checkbox"/>	70540	#10-24 Hex Nut, Zn Plated	7
<input type="checkbox"/>	70641	#10 Regular Lockwasher, Zn Plated	4
<input type="checkbox"/>	70801	1/4 x 1 1/4 Square Key	2
<input type="checkbox"/>	70913	#10-24 x 3/4" lg Machine Screw, Slotted Round Head, Plain Finish	4

Model 59282 5 HP 1 Electric Motor

1	210014	Countershaft Pulley	1
2	5994	15T Countershaft Sprocket	1
3	5082	Countershaft Pillow Block Bearing	2
4	5341	Electric Motor, 5HP Single Phase	1
5	5464	Countershaft for Electric Motor Kit	1
6	5466	Countershaft Bracket Assembly	1
7	5591	V-Belt	2
8	5887	Sheave	1
9	5990	#60 Riveted Type Roller Chain, 4.0 FT (Includes links listed below)	1
10	19778	#60 Connecting Link (Included with Item #9)	1
11	19779	#60 Offset Link (Included with Item #9)	1
<input type="checkbox"/>	70235	3/8-16 x 1" lg GR 5 HHCS Zn Plated	4
<input type="checkbox"/>	70238	3/8-16 x 1 1/8" lg GR 5 HHCS Zn Plated	12
<input type="checkbox"/>	70390	#10-24 x 1 1/4" lg Machine Screw, Slotted Round Head, Plain Finish	3
<input type="checkbox"/>	70500	5/16-18 x 1/2" lg Socket Head Cup Set Screw	1
<input type="checkbox"/>	70540	#10-24 Hex Nut, Zn Plated	7
<input type="checkbox"/>	70641	#10 Regular Lockwasher, Zn Plated	4
<input type="checkbox"/>	70801	1/4 x 1 1/4 Square Key	2
<input type="checkbox"/>	70913	#10-24 x 3/4" lg Machine Screw, Slotted Round Head, Plain Finish	4
<input type="checkbox"/>	70800	1/4 x 1 Square Key	1
<input type="checkbox"/>	70049	#1/4-20 x 3/4" Square Head Cup Set Screw, Gr5	2

Not Shown - Use Local Source